

FULLY THREADED SCREW WITH COUNTERSUNK OR HEXAGONAL HEAD

3 THORNS TIP

Thanks to the 3 THORNS tip, minimum installation distances are reduced. More screws can be used in less space and larger screws in smaller elements.

Costs and time for project implementation are reduced.

CERTIFICATION FOR TIMBER AND CONCRETE

Structural connector approved for timber applications according to ETA-11/0030 and for timber-concrete applications according to ETA-22/0806.

TENSILE STRENGTH

Deep thread and high strength steel for excellent tensile or sliding performance. Approved for structural applications subject to stresses in any direction vs the grain ($0^\circ \div 90^\circ$).

Can be used on steel plates in combination with the VGU and HUS washers.

COUNTERSUNK OR HEXAGONAL HEAD

Countersunk head up to L = 600 mm, ideal for use on plates or for concealed reinforcements. Hexagonal head L > 600 mm to facilitate gripping with screwdriver.

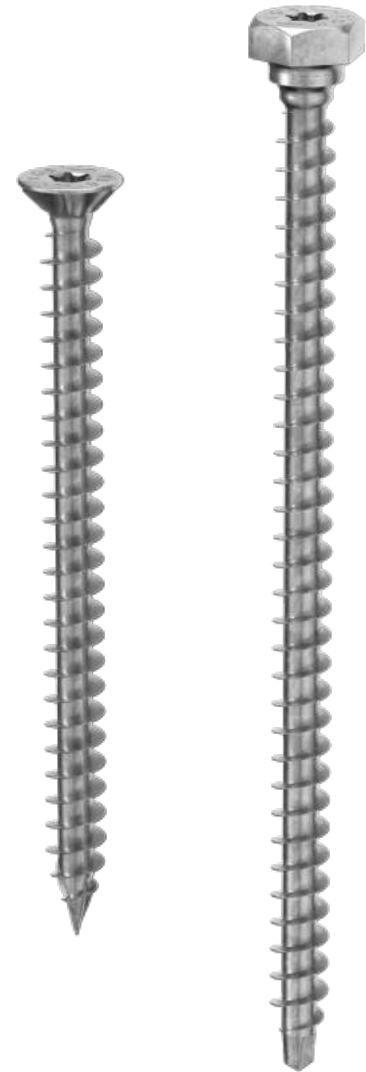

BIT INCLUDED

DIAMETER [mm]	9 (9) 15 15
LENGTH [mm]	80 (80) 2000 2000
SERVICE CLASS	SC1 SC2
ATMOSPHERIC CORROSIVITY	C1 C2
WOOD CORROSIVITY	T1 T2
MATERIAL	Zn ELECTRO PLATED electrogalvanized carbon steel

METAL-to-TIMBER recommended use:

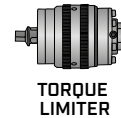

FIELDS OF USE

- timber based panels
- solid timber
- glulam (Glued Laminated Timber)
- CLT and LVL
- high density woods



TC FUSION

The ETA-22/0806 approval of the TC FUSION system allows the VGS screws to be used together with the reinforcements in the concrete so that the panel floor slabs and the bracing core can be bonded together with a small integration of the casting.

GEOMETRY AND MECHANICAL CHARACTERISTICS

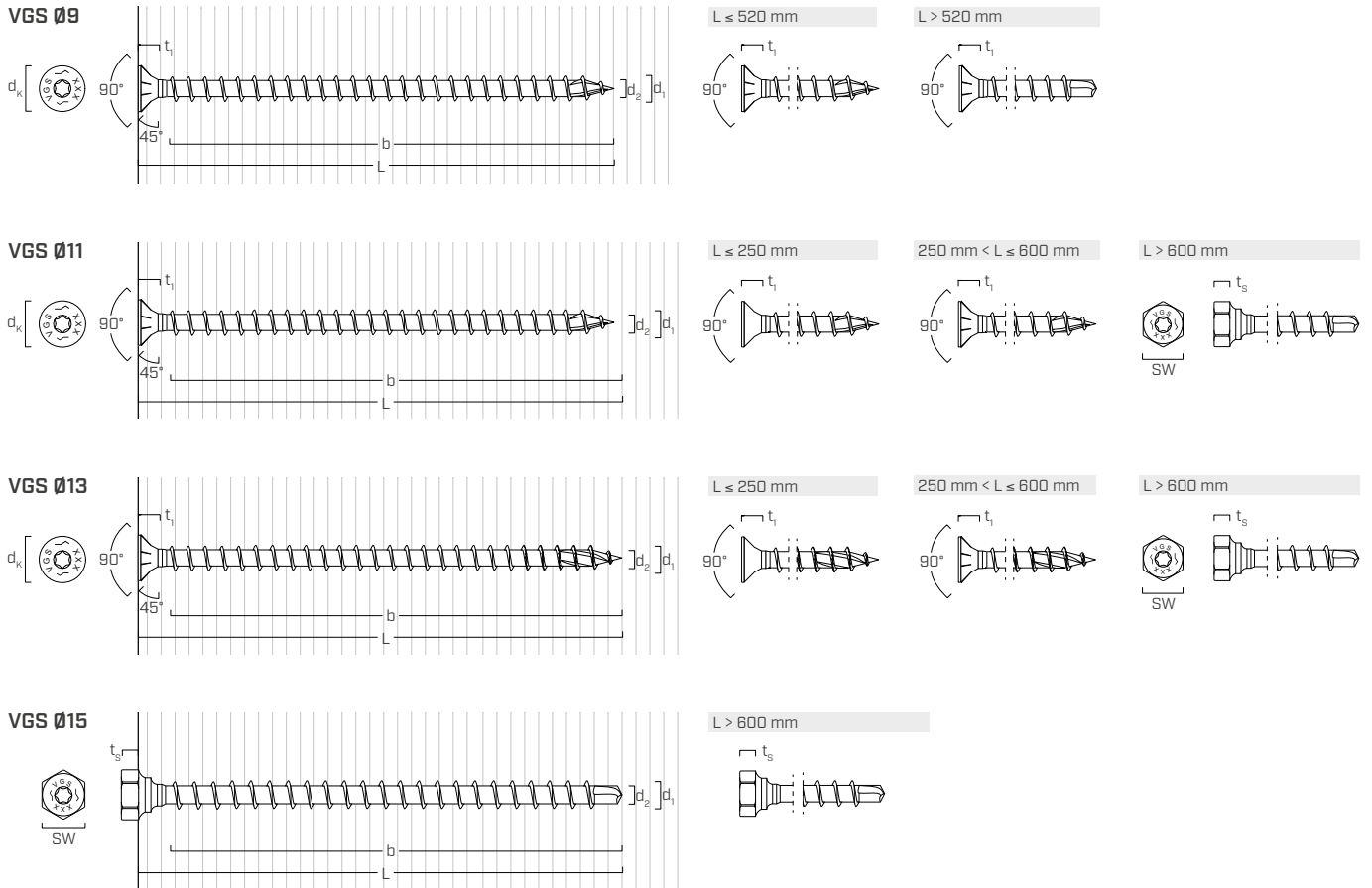

Nominal diameter	d_1	[mm]	9	11	11	13	13	15
Length	L	[mm]	-	≤ 600 mm	> 600 mm	≤ 600 mm	> 600 mm	-
Countersunk head diameter	d_k	[mm]	16,00	19,30	-	22,00	-	-
Countersunk head thickness	t_1	[mm]	6,50	8,20	-	9,40	-	-
Wrench size	SW	-	-	-	SW 17	-	SW 19	SW22
Hexagonal head thickness	t_s	[mm]	-	-	6,40	-	7,50	8,80
Thread diameter	d_2	[mm]	5,90	6,60	6,60	8,00	8,00	9,10
Pre-drilling hole diameter ⁽¹⁾	$d_{v,S}$	[mm]	5,0	6,0	6,0	8,0	8,0	9,00
Pre-drilling hole diameter ⁽²⁾	$d_{v,H}$	[mm]	6,0	7,0	7,0	9,0	9,0	10,00
Characteristic tensile strength	$f_{tens,k}$	[kN]	25,4	38,0	38,0	53,0	53,0	65,0
Characteristic yield moment	$M_{y,k}$	[Nm]	27,2	45,9	45,9	70,9	70,9	95,0
Characteristic yield strength	$f_{y,k}$	[N/mm ²]	1000	1000	1000	1000	1000	1000

(1) Pre-drilling valid for softwood.

(2) Pre-drilling valid for hardwood and beech LVL.

The mechanical parameters for VGS Ø15 are obtained analytically and validated by experimental tests.

			softwood (softwood)	LVL softwood (LVL softwood)	pre-drilled beech LVL (beech LVL predrilled)
Withdrawal resistance parameter	$f_{ax,k}$	[N/mm ²]	11,7	15,0	29,0
Associated density	ρ_a	[kg/m ³]	350	500	730
Calculation density	ρ_k	[kg/m ³]	≤ 440	410 ÷ 550	590 ÷ 750

For applications with different materials please see ETA-11/0030.

TC FUSION SYSTEM FOR TIMBER-CONCRETE APPLICATION

Nominal diameter	d_1	[mm]	9	11	13	15
Tangential strength of adhesion in concrete C25/30	$f_{b,k}$	[N/mm ²]	12,5	12,5	12,5	-

For applications with different materials please see ETA-22/0806

CODES AND DIMENSIONS

d ₁ [mm]	CODE	L [mm]	b [mm]	pcs
9 TX40	VGS9100	100	90	25
	VGS9120	120	110	25
	VGS9140	140	130	25
	VGS9160	160	150	25
	VGS9180	180	170	25
	VGS9200	200	190	25
	VGS9220	220	210	25
	VGS9240	240	230	25
	VGS9260	260	250	25
	VGS9280	280	270	25
	VGS9300	300	290	25
	VGS9320	320	310	25
	VGS9340	340	330	25
	VGS9360	360	350	25
	VGS9380	380	370	25
	VGS9400	400	390	25
	VGS9440	440	430	25
	VGS9480	480	470	25
	VGS9520	520	510	25
	VGS9560	560	550	25
VGS9600	600	590	25	
11 TX 50	VGS1180	80	70	25
	VGS11100	100	90	25
	VGS11125	125	115	25
	VGS11150	150	140	25
	VGS11175	175	165	25
	VGS11200	200	190	25
	VGS11225	225	215	25
	VGS11250	250	240	25
	VGS11275	275	265	25
	VGS11300	300	290	25
	VGS11325	325	315	25
	VGS11350	350	340	25
	VGS11375	375	365	25
	VGS11400	400	390	25
	VGS11425	425	415	25
	VGS11450	450	440	25
	VGS11475	475	465	25
	VGS11500	500	490	25
	VGS11525	525	515	25
	VGS11550	550	540	25
VGS11575	575	565	25	
VGS11600	600	590	25	
VGS11650	650	630	25	
VGS11700	700	680	25	
VGS11750	750	680	25	
VGS11800	800	780	25	
VGS11850	850	830	25	
VGS11900	900	880	25	
VGS11950	950	930	25	
VGS111000	1000	980	25	

d ₁ [mm]	CODE	L [mm]	b [mm]	pcs
13 TX 50	VGS1380	80	70	25
	VGS13100	100	90	25
	VGS13150	150	140	25
	VGS13200	200	190	25
	VGS13250	250	240	25
	VGS13300	300	280	25
	VGS13350	350	330	25
	VGS13400	400	380	25
	VGS13450	450	430	25
	VGS13500	500	480	25
VGS13550	550	530	25	
VGS13600	600	580	25	
VGS13650	650	630	25	
VGS13700	700	680	25	
VGS13750	750	730	25	
VGS13800	800	780	25	
VGS13850	850	830	25	
VGS13900	900	880	25	
VGS13950	950	930	25	
VGS131000	1000	980	25	
VGS131100	1100	1080	25	
VGS131200	1200	1180	25	
VGS131300	1300	1280	25	
VGS131400	1400	1380	25	
VGS131500	1500	1480	25	
VGS15600	600	580	25	
VGS15700	700	680	25	
VGS15800	800	780	25	
VGS15900	900	880	25	
VGS151000	1000	980	25	
VGS151200	1200	1180	25	
VGS151400	1400	1380	25	
VGS151600	1600	1580	25	
VGS151800	1800	1780	25	
VGS152000	2000	1980	25	

RELATED PRODUCTS



VGU

45° WASHER FOR VGS

page 190



TORQUE LIMITER

TORQUE LIMITER

page 408



WASP

HOOK FOR TIMBER ELEMENTS
TRANSPORT

page 413

MINIMUM DISTANCES FOR AXIAL STRESSES

😊 screws inserted **WITH** and **WITHOUT** pre-drilled hole

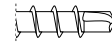
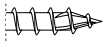

d_1	[mm]	9	11	
a_1	[mm]	5·d	45	55
a_2	[mm]	5·d	45	55
$a_{2,LIM}$	[mm]	2,5·d	23	28
$a_{1,CG}$	[mm]	8·d	72	88
$a_{2,CG}$	[mm]	3·d	27	33
a_{CROSS}	[mm]	1,5·d	14	17

d_1	[mm]	13	
a_1	[mm]	5·d	65
a_2	[mm]	5·d	65
$a_{2,LIM}$	[mm]	2,5·d	33
$a_{1,CG}$	[mm]	8·d	104
$a_{2,CG}$	[mm]	3·d	39
a_{CROSS}	[mm]	1,5·d	20

d_1	[mm]	9	11	13	15	
a_1	[mm]	5·d	45	55	65	75
a_2	[mm]	5·d	45	55	65	75
$a_{2,LIM}$	[mm]	2,5·d	23	28	33	38
$a_{1,CG}$	[mm]	5·d	45	55	65	150
$a_{2,CG}$	[mm]	3·d	27	33	39	60
a_{CROSS}	[mm]	1,5·d	14	17	20	23

SCREWS UNDER TENSION INSERTED WITH AN ANGLE α WITH RESPECT TO THE GRAIN

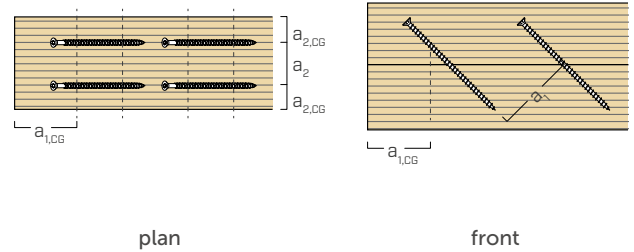
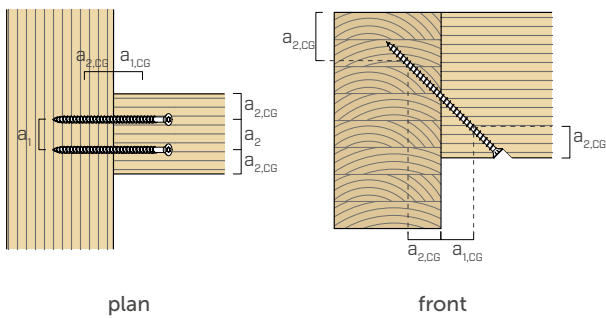

SCREWS INSERTED WITH $\alpha = 90^\circ$ ANGLE WITH RESPECT TO THE GRAIN

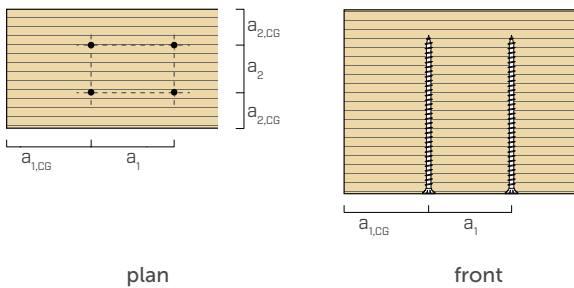

CROSS SCREWS INSERTED WITH AN ANGLE α WITH RESPECT TO THE GRAIN

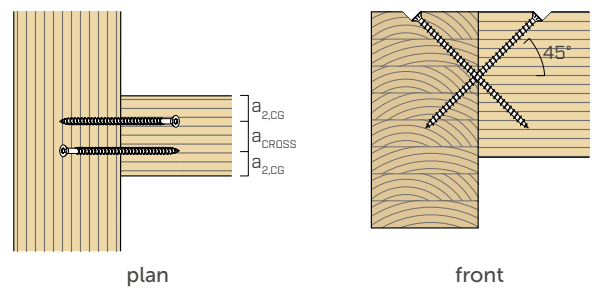

NOTES

- Minimum distances according to ETA-11/0030.
- The minimum distances are independent of the insertion angle of the connector and the angle of the force with respect to the grain.
- The axial distance a_2 can be reduced down to $a_{2,LIM}$ if for each connector a "joint surface" $a_1 \cdot a_2 = 25 \cdot d_1^2$ is maintained.
- For 3 THORNS tip, RBSN and self-drilling tip screws, the minimum distances in the table are derived from experimental tests; alternatively, adopt $a_{1,CG} = 10 \cdot d$ and $a_{2,CG} = 4 \cdot d$ in accordance with EN 1995:2014.

EFFECTIVE THREAD USED IN CALCULATION

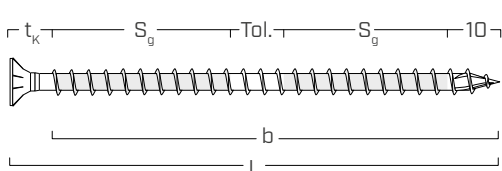

$$b = S_{g,tot} = L - t_k$$

$$S_g = (L - t_k - 10 \text{ mm} - Tol.) / 2$$

$$t_k = 10 \text{ mm (countersunk head)}$$

$$t_k = 20 \text{ mm (hexagonal head)}$$

represents the entire length of the threaded part

represents the partial length of the threaded part net of a laying tolerance (Tol.) of 10 mm

MINIMUM DISTANCES FOR SHEAR LOADS

screws inserted **WITHOUT** pre-drilled hole $\rho_k \leq 420 \text{ kg/m}^3$

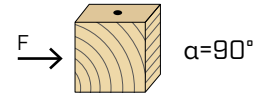
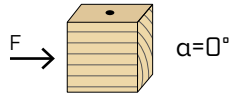

d_1 [mm]		9	11	13	15
a_1 [mm]	10·d	90	110	130	150
a_2 [mm]	5·d	45	55	65	75
$a_{3,t}$ [mm]	15·d	135	165	195	225
$a_{3,c}$ [mm]	10·d	90	110	130	150
$a_{4,t}$ [mm]	5·d	45	55	65	75
$a_{4,c}$ [mm]	5·d	45	55	65	75

d_1 [mm]		9	11	13	15
a_1 [mm]	5·d	45	55	65	75
a_2 [mm]	5·d	45	55	65	75
$a_{3,t}$ [mm]	10·d	90	110	130	150
$a_{3,c}$ [mm]	10·d	90	110	130	150
$a_{4,t}$ [mm]	10·d	90	110	130	150
$a_{4,c}$ [mm]	5·d	45	55	65	75

screws inserted **WITH** pre-drilled hole

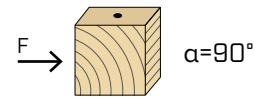
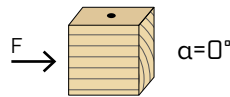

d_1 [mm]		9	11	13	15
a_1 [mm]	5·d	45	55	65	75
a_2 [mm]	3·d	27	33	39	45
$a_{3,t}$ [mm]	12·d	108	132	156	180
$a_{3,c}$ [mm]	7·d	63	77	91	105
$a_{4,t}$ [mm]	3·d	27	33	39	45
$a_{4,c}$ [mm]	3·d	27	33	39	45

d_1 [mm]		9	11	13	15
a_1 [mm]	4·d	36	44	52	60
a_2 [mm]	4·d	36	44	52	60
$a_{3,t}$ [mm]	7·d	63	77	91	105
$a_{3,c}$ [mm]	7·d	63	77	91	105
$a_{4,t}$ [mm]	7·d	63	77	91	105
$a_{4,c}$ [mm]	3·d	27	33	39	45

α = load-to-grain angle
 d = d_1 = nominal screw diameter

stressed end
 $-90^\circ < \alpha < 90^\circ$

unloaded end
 $90^\circ < \alpha < 270^\circ$

stressed edge
 $0^\circ < \alpha < 180^\circ$

unload edge
 $180^\circ < \alpha < 360^\circ$

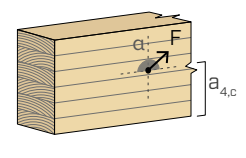
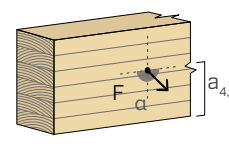
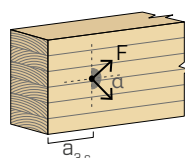
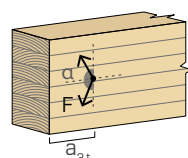
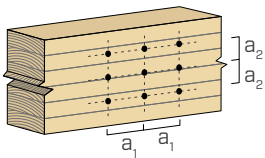

NOTES

- Minimum distances are in accordance with EN 1995:2014 as per ETA-11/0030 considering a timber characteristic density of $\rho_k \leq 420 \text{ kg/m}^3$.
- The minimum spacing for all steel-to-timber connections (a_1 , a_2) can be multiplied by a coefficient of 0,7.
- The minimum spacing for all panel-to-timber connections (a_1 , a_2) can be multiplied by a coefficient of 0,85.
- The spacing a_1 in the table for screws with 3 THORNS tip inserted without pre-drilling hole in timber elements with density $\rho_k \leq 420 \text{ kg/m}^3$ and load-to-grain angle $\alpha=0^\circ$ was assumed to be 10·d based on experimental tests; alternatively, adopt 12·d in accordance with EN 1995:2014.

EFFECTIVE NUMBER FOR SHEAR LOADS

The load-bearing capacity of a connection made with several screws, all of the same type and size, may be lower than the sum of the load-bearing capacities of the individual connection system. For a row of n screws arranged parallel to the direction of the grain at a distance a_1 , the characteristic effective load-bearing capacity is equal to:

$$R_{ef,V,k} = n_{ef} \cdot R_{V,k}$$

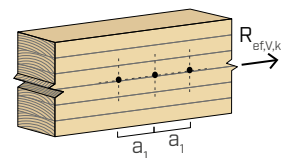

The n_{ef} value is given in the table below as a function of n and a_1 .

n	a_1 (*)										
	4·d	5·d	6·d	7·d	8·d	9·d	10·d	11·d	12·d	13·d	$\geq 14\cdot d$
2	1,41	1,48	1,55	1,62	1,68	1,74	1,80	1,85	1,90	1,95	2,00
3	1,73	1,86	2,01	2,16	2,28	2,41	2,54	2,65	2,76	2,88	3,00
4	2,00	2,19	2,41	2,64	2,83	3,03	3,25	3,42	3,61	3,80	4,00
5	2,24	2,49	2,77	3,09	3,34	3,62	3,93	4,17	4,43	4,71	5,00

(*)For intermediate a_1 values a linear interpolation is possible.

TENSION / COMPRESSION

geometry		TENSION / COMPRESSION								steel tension	instability $\epsilon=90^\circ$
		total thread withdrawal				partial thread withdrawal					
		$\epsilon=90^\circ$		$\epsilon=0^\circ$		$\epsilon=90^\circ$		$\epsilon=0^\circ$			
d_1 [mm]	L [mm]	$S_{g,tot}$ [mm]	A_{min} [mm]	$R_{ax,90,k}$ [kN]	$R_{ax,0,k}$ [kN]	S_g [mm]	A_{min} [mm]	$R_{ax,90,k}$ [kN]	$R_{ax,0,k}$ [kN]	$R_{tens,k}$ [kN]	$R_{ki,90,k}$ [kN]
9	100	90	110	10,23	3,07	35	55	3,98	1,19	25,40	17,25
	120	110	130	12,50	3,75	45	65	5,11	1,53		
	140	130	150	14,77	4,43	55	75	6,25	1,88		
	160	150	170	17,05	5,11	65	85	7,39	2,22		
	180	170	190	19,32	5,80	75	95	8,52	2,56		
	200	190	210	21,59	6,48	85	105	9,66	2,90		
	220	210	230	23,87	7,16	95	115	10,80	3,24		
	240	230	250	26,14	7,84	105	125	11,93	3,58		
	260	250	270	28,41	8,52	115	135	13,07	3,92		
	280	270	290	30,68	9,21	125	145	14,21	4,26		
	300	290	310	32,96	9,89	135	155	15,34	4,60		
	320	310	330	35,23	10,57	145	165	16,48	4,94		
	340	330	350	37,50	11,25	155	175	17,61	5,28		
	360	350	370	39,78	11,93	165	185	18,75	5,63		
	380	370	390	42,05	12,61	175	195	19,89	5,97		
	400	390	410	44,32	13,30	185	205	21,02	6,31		
	440	430	450	48,87	14,66	205	225	23,30	6,99		
	480	470	490	53,41	16,02	225	245	25,57	7,67		
520	510	530	57,96	17,39	245	265	27,84	8,35			
560	550	570	62,50	18,75	265	285	30,12	9,03			
600	590	610	67,05	20,11	285	305	32,39	9,72			
11	80	70	90	9,72	2,92	25	45	3,47	1,04	38,00	21,93
	100	90	110	12,50	3,75	35	55	4,86	1,46		
	125	115	135	15,97	4,79	48	68	6,60	1,98		
	150	140	160	19,45	5,83	60	80	8,33	2,50		
	175	165	185	22,92	6,88	73	93	10,07	3,02		
	200	190	210	26,39	7,92	85	105	11,81	3,54		
	225	215	235	29,86	8,96	98	118	13,54	4,06		
	250	240	260	33,34	10,00	110	130	15,28	4,58		
	275	265	285	36,81	11,04	123	143	17,01	5,10		
	300	290	310	40,28	12,08	135	155	18,75	5,63		
	325	315	335	43,75	13,13	148	168	20,49	6,15		
	350	340	360	47,22	14,17	160	180	22,22	6,67		
	375	365	385	50,70	15,21	173	193	23,96	7,19		
	400	390	410	54,17	16,25	185	205	25,70	7,71		
	425	415	435	57,64	17,29	198	218	27,43	8,23		
	450	440	460	61,11	18,33	210	230	29,17	8,75		
	475	465	485	64,59	19,38	223	243	30,90	9,27		
	500	490	510	68,06	20,42	235	255	32,64	9,79		
	525	515	535	71,53	21,46	248	268	34,38	10,31		
	550	540	560	75,00	22,50	260	280	36,11	10,83		
	575	565	585	78,48	23,54	273	293	37,85	11,35		
	600	590	610	81,95	24,58	285	305	39,59	11,88		
650	630	660	87,51	26,25	305	325	42,36	12,71			
700	680	710	94,45	28,33	330	350	45,84	13,75			
750	680	760	94,45	28,33	330	350	45,84	13,75			
800	780	810	108,34	32,50	380	400	52,78	15,83			
850	830	860	115,28	34,59	405	425	56,25	16,88			
900	880	910	122,23	36,67	430	450	59,73	17,92			
950	930	960	129,17	38,75	455	475	63,20	18,96			
1000	980	1010	136,12	40,84	480	500	66,67	20,00			

TENSION / COMPRESSION

geometry		total thread withdrawal				partial thread withdrawal				steel tension	instability $\epsilon=90^\circ$
		$\epsilon=90^\circ$		$\epsilon=0^\circ$		$\epsilon=90^\circ$		$\epsilon=0^\circ$			
d_1 [mm]	L [mm]	$S_{g,tot}$ [mm]	A_{min} [mm]	$R_{ax,90,k}$ [kN]	$R_{ax,0,k}$ [kN]	S_g [mm]	A_{min} [mm]	$R_{ax,90,k}$ [kN]	$R_{ax,0,k}$ [kN]	$R_{tens,k}$ [kN]	$R_{ki,90,k}$ [kN]
13	80	70	90	11,49	3,45	25	45	4,10	1,23	53,00	32,69
	100	90	110	14,77	4,43	35	55	5,75	1,72		
	150	140	160	22,98	6,89	60	80	9,85	2,95		
	200	190	210	31,19	9,36	85	105	13,95	4,19		
	250	240	260	39,40	11,82	110	130	18,06	5,42		
	300	280	310	45,96	13,79	130	150	21,34	6,40		
	350	330	360	54,17	16,25	155	175	25,44	7,63		
	400	380	410	62,38	18,71	180	200	29,55	8,86		
	450	430	460	70,58	21,18	205	225	33,65	10,10		
	500	480	510	78,79	23,64	230	250	37,75	11,33		
	550	530	560	87,00	26,10	255	275	41,86	12,56		
	600	580	610	95,21	28,56	280	300	45,96	13,79		
	650	630	660	103,42	31,02	305	325	50,07	15,02		
	700	680	710	111,62	33,49	330	350	54,17	16,25		
	750	730	760	119,83	35,95	355	375	58,27	17,48		
	800	780	810	128,04	38,41	380	400	62,38	18,71		
	850	830	860	136,25	40,87	405	425	66,48	19,94		
	900	880	910	144,45	43,34	430	450	70,58	21,18		
	950	930	960	152,66	45,80	455	475	74,69	22,41		
	1000	980	1010	160,87	48,26	480	500	78,79	23,64		
1100	1080	1110	177,28	53,18	530	550	87,00	26,10			
1200	1180	1210	193,70	58,11	580	600	95,21	28,56			
1300	1280	1310	210,11	63,03	630	650	103,42	31,02			
1400	1380	1410	226,53	67,96	680	700	111,62	33,49			
1500	1480	1510	242,94	72,88	730	750	119,83	35,95			
15	600	580	610	109,85	32,96	280	300	53,03	15,91	65,00	42,86
	700	680	710	128,80	38,64	330	350	62,50	18,75		
	800	780	810	147,74	44,32	380	400	71,97	21,59		
	900	880	910	166,68	50,00	430	450	81,44	24,43		
	1000	980	1010	185,62	55,69	480	500	90,91	27,27		
	1200	1180	1210	223,50	67,05	580	600	109,85	32,96		
	1400	1380	1410	261,38	78,41	680	700	128,80	38,64		
	1600	1580	1610	299,26	89,78	780	800	147,74	44,32		
	1800	1780	1810	337,14	101,14	880	900	166,68	50,00		
	2000	1980	2010	375,02	112,51	980	1000	185,62	55,69		

ϵ = screw-to-grain angle

geometry		SLIDING									SHEAR			
		timber-to-timber				steel-to-timber				steel tension	timber-to-timber $\varepsilon=90^\circ$		timber-to-timber $\varepsilon=0^\circ$	
d_1 [mm]	L [mm]	S_g [mm]	A [mm]	B_{min} [mm]	$R_{V,k}$ [kN]	S_{PLATE} [mm]	S_g [mm]	A_{min} [mm]	$R_{V,k}$ [kN]	$R_{tens,45,k}$ [kN]	S_g [mm]	A [mm]	$R_{V,90,k}$ [kN]	$R_{V,0,k}$ [kN]
9	100	35	40	55	2,81	15	85	80	6,83	17,96	35	50	4,04	2,07
	120	45	45	60	3,62		105	95	8,44		45	60	4,53	2,30
	140	55	55	70	4,42		125	110	10,04		55	70	4,81	2,55
	160	65	60	75	5,22		145	125	11,65		65	80	5,10	2,81
	180	75	70	85	6,03		165	135	13,26		75	90	5,38	3,08
	200	85	75	90	6,83		185	150	14,87		85	100	5,67	3,18
	220	95	85	100	7,63		205	165	16,47		95	110	5,95	3,27
	240	105	90	105	8,44		225	180	18,08		105	120	6,23	3,35
	260	115	95	110	9,24		245	195	19,69		115	130	6,50	3,44
	280	125	105	120	10,04		265	205	21,29		125	140	6,50	3,52
	300	135	110	125	10,85		285	220	22,90		135	150	6,50	3,61
	320	145	120	135	11,65		305	235	24,51		145	160	6,50	3,69
	340	155	125	140	12,46		325	250	26,12		155	170	6,50	3,78
	360	165	130	145	13,26		345	265	27,72		165	180	6,50	3,86
	380	175	140	155	14,06		365	280	29,33		175	190	6,50	3,95
	400	185	145	160	14,87		385	290	30,94		185	200	6,50	4,03
	440	205	160	175	16,47		425	320	34,15		205	220	6,50	4,21
	480	225	175	190	18,08		465	350	37,37		225	240	6,50	4,38
520	245	190	205	19,69	505	375	40,58	245	260	6,50	4,55			
560	265	205	220	21,29	545	405	43,79	265	280	6,50	4,72			
600	285	215	230	22,90	585	435	47,01	285	300	6,50	4,89			
11	80	25	35	50	2,46	18	60	60	5,89	26,87	25	40	3,67	2,16
	100	35	40	55	3,44		80	75	7,86		35	50	4,72	2,69
	125	48	50	65	4,67		105	95	10,31		48	63	6,03	2,99
	150	60	60	75	5,89		130	110	12,77		60	75	6,61	3,33
	175	73	65	80	7,12		155	130	15,22		73	88	7,05	3,71
	200	85	75	90	8,35		180	145	17,68		85	100	7,48	4,10
	225	98	85	100	9,58		205	165	20,13		98	113	7,92	4,44
	250	110	95	110	10,80		230	185	22,59		110	125	8,35	4,57
	275	123	100	115	12,03		255	200	25,04		123	138	8,79	4,70
	300	135	110	125	13,26		280	220	27,50		135	150	9,06	4,83
	325	148	120	135	14,49		305	235	29,96		148	163	9,06	4,96
	350	160	130	145	15,71		330	255	32,41		160	175	9,06	5,09
	375	173	140	155	16,94		355	270	34,87		173	188	9,06	5,22
	400	185	145	160	18,17		380	290	37,32		185	200	9,06	5,35
	425	198	155	170	19,40		405	305	39,78		198	213	9,06	5,48
	450	210	165	180	20,63		430	325	42,23		210	225	9,06	5,61
	475	223	175	190	21,85		455	340	44,69		223	238	9,06	5,74
	500	235	180	195	23,08		480	360	47,14		235	250	9,06	5,87
	525	248	190	205	24,31		505	375	49,60		248	263	9,06	6,00
	550	260	200	215	25,54		530	395	52,05		260	275	9,06	6,13
	575	273	210	225	26,76		555	410	54,51		273	288	9,06	6,26
	600	285	215	230	27,99		580	430	56,96		285	300	9,06	6,39
	650	305	230	245	29,96		-	-	-		305	320	9,06	6,60
	700	330	250	265	32,41		-	-	-		330	345	9,06	6,85
750	330	250	265	32,41	-	-	-	330	345	9,06	6,85			
800	380	285	300	37,32	-	-	-	380	395	9,06	6,85			
850	405	300	315	39,78	-	-	-	405	420	9,06	6,85			
900	430	320	335	42,23	-	-	-	430	445	9,06	6,85			
950	455	335	350	44,69	-	-	-	455	470	9,06	6,85			
1000	480	355	370	47,14	-	-	-	480	495	9,06	6,85			

geometry		SLIDING									SHEAR			
		timber-to-timber				steel-to-timber				steel tension	timber-to-timber $\epsilon=90^\circ$		timber-to-timber $\epsilon=0^\circ$	
d_1 [mm]	L [mm]	S_g [mm]	A [mm]	B_{min} [mm]	$R_{V,k}$ [kN]	S_{PLATE} [mm]	S_g [mm]	A_{min} [mm]	$R_{V,k}$ [kN]	$R_{tens,45,k}$ [kN]	S_g [mm]	A [mm]	$R_{V,90,k}$ [mm]	$R_{V,0,k}$ [kN]
13	80	25	35	50	2,90	20	60	60	6,96	37,48	25	40	4,18	2,44
	100	35	40	55	4,06		80	75	9,29		35	50	5,37	3,10
	150	60	60	75	6,96		130	110	15,09		60	75	8,37	4,06
	200	85	75	90	9,87		180	145	20,89		85	100	9,46	4,88
	250	110	95	110	12,77		230	185	26,70		110	125	10,49	5,77
	300	130	110	125	15,09		280	220	32,50		130	145	11,31	6,11
	350	155	125	140	17,99		330	255	38,30		155	170	11,94	6,42
	400	180	145	160	20,89		380	290	44,11		180	195	11,94	6,73
	450	205	160	175	23,79		430	325	49,91		205	220	11,94	7,04
	500	230	180	195	26,70		480	360	55,71		230	245	11,94	7,35
	550	255	195	210	29,60		530	395	61,52		255	270	11,94	7,65
	600	280	215	230	32,50		580	430	67,32		280	295	11,94	7,96
	650	305	230	245	35,40		-	-	-		305	320	11,94	8,27
	700	330	250	265	38,30		-	-	-		330	345	11,94	8,58
	750	355	265	280	41,21		-	-	-		355	370	11,94	8,88
	800	380	285	300	44,11		-	-	-		380	395	11,94	9,03
	850	405	300	315	47,01		-	-	-		405	420	11,94	9,03
	900	430	320	335	49,91		-	-	-		430	445	11,94	9,03
	950	455	335	350	52,81		-	-	-		455	470	11,94	9,03
	1000	480	355	370	55,71		-	-	-		480	495	11,94	9,03
1100	530	390	405	61,52	-	-	-	530	545	11,94	9,03			
1200	580	425	440	67,32	-	-	-	580	595	11,94	9,03			
1300	630	460	475	73,13	-	-	-	630	645	11,94	9,03			
1400	680	495	510	78,93	-	-	-	680	695	11,94	9,03			
1500	730	530	545	84,73	-	-	-	730	745	11,94	9,03			
15	600	280	215	230	37,50	-	-	-	-	45,96	280	295	14,53	9,47
	700	330	250	265	44,20		-	-	-		330	345	14,53	10,18
	800	380	285	300	50,89		-	-	-		380	395	14,53	10,89
	900	430	320	335	57,59		-	-	-		430	445	14,53	10,99
	1000	480	355	370	64,29		-	-	-		480	495	14,53	10,99
	1200	580	425	440	77,68		-	-	-		580	595	14,53	10,99
	1400	680	495	510	91,07		-	-	-		680	695	14,53	10,99
	1600	780	565	580	104,47		-	-	-		780	795	14,53	10,99
	1800	880	640	655	117,86		-	-	-		880	895	14,53	10,99
	2000	980	710	725	131,25		-	-	-		980	995	14,53	10,99

ϵ = screw-to-grain angle

STRUCTURAL VALUES | FURTHER APPLICATIONS

**SHEAR CONNECTION
WITH CROSSED CONNECTORS**

VGS Ø9 - 11 mm

STRUCTURAL VALUES on page 130.

**SLIDING CONNECTION
WITH VGU WASHER**

VGS Ø9 - 11 - 13 mm

STRUCTURAL VALUES on page 192.

**CONNECTIONS WITH
CLT ELEMENTS**

VGS Ø9 - 11 mm

STRUCTURAL VALUES on page 134.

**CONNECTIONS WITH
LVL ELEMENTS**

VGS Ø9 - 11 mm

STRUCTURAL VALUES on page 138.

EFFECTIVE NUMBER FOR AXIAL STRESSES

The load-bearing capacity of a connection made with several screws, all of the same type and size, may be lower than the sum of the load-bearing capacities of the individual connection system.

For a connection with inclined screws, the characteristic effective sliding load-bearing capacity for a row of n screws is equal to:

$$R_{ef,V,k} = n_{ef,ax} \cdot R_{V,k}$$

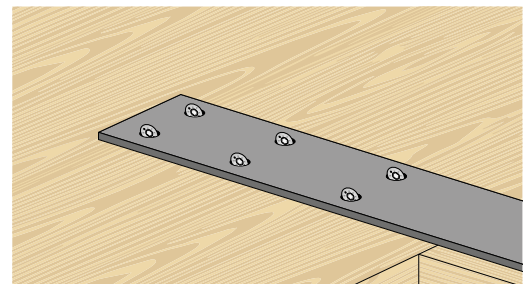

The n_{ef} value is given in the table below as a function of n (number of screws in a row).

n	2	3	4	5	6	7	8	9	10
$n_{ef,ax}$	1,87	2,70	3,60	4,50	5,40	6,30	7,20	8,10	9,00



Complete calculation reports for designing in wood?
Download MyProject and simplify your work!



TENSILE CONNECTION
CLT - CONCRETE

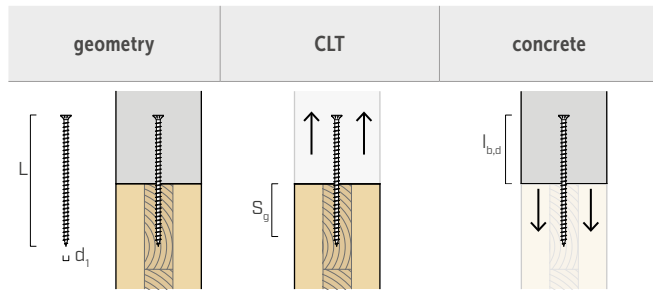

d_1 [mm]	L [mm]	S_g [mm]	$R_{ax,0,k}$ [kN]	$l_{b,d}$ [mm]	$R_{ax,C,k}$ [kN]		
9	200	85	6,32	100	35,34		
	220	105	7,65	100			
	240	125	8,95	100			
	260	145	10,22	100			
	280	165	11,49	100			
	300	185	12,73	100			
	320	205	13,96	100			
	340	225	15,18	100			
	360	245	16,39	100			
	380	265	17,59	100			
	400	285	18,78	100			
	440	325	21,14	100			
	480	365	23,47	100			
	520	405	25,40	100			
	560	445	25,40	100			
	600	485	25,40	100			
	11	225	110	9,36		100	43,20
		250	135	11,26		100	
275		160	13,12	100			
300		185	14,95	100			
325		210	16,75	100			
350		235	18,54	100			
375		260	20,31	100			
400		285	22,05	100			
425		310	23,79	100			
450		335	25,51	100			
475		360	27,22	100			
500		385	28,91	100			
525		410	30,59	100			
550		435	32,27	100			
575		460	33,93	100			
600		485	35,59	100			
650		535	38,00	100			
700		585	38,00	100			
750	635	38,00	100				
800	685	38,00	100				
850	735	38,00	100				
900	785	38,00	100				
950	835	38,00	100				
1000	885	38,00	100				

TENSILE CONNECTION
CLT - CONCRETE

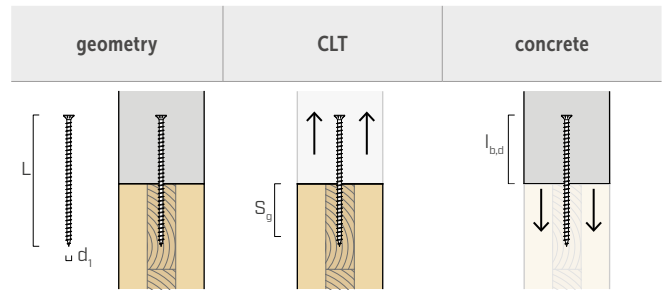

d_1 [mm]	L [mm]	S_g [mm]	$R_{ax,0,k}$ [kN]	$l_{b,d}$ [mm]	$R_{ax,C,k}$ [kN]
13	300	165	15,41	120	61,26
	350	215	19,56	120	
	400	265	23,61	120	
	450	315	27,58	120	
	500	365	31,50	120	
	550	415	35,35	120	
	600	465	39,16	120	
	650	515	42,93	120	
	700	565	46,67	120	
	750	615	50,37	120	
	800	665	53,00	120	
	850	715	53,00	120	
	900	765	53,00	120	
	950	815	53,00	120	
	1000	865	53,00	120	
	1100	965	53,00	120	
	1200	1065	53,00	120	
	1300	1165	53,00	120	
1400	1265	53,00	120		
1500	1365	53,00	120		

NOTES and GENERAL PRINCIPLES on page 176.

TC FUSION

TIMBER-TO-CONCRETE JOINT SYSTEM

The innovation of VGS, VGZ and RTR all-thread connectors for timber-concrete applications.

Find it out on page 270.

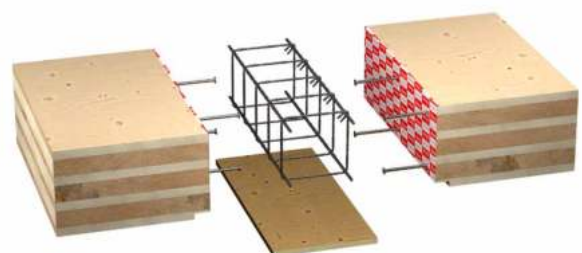

STRUCTURAL VALUES

GENERAL PRINCIPLES

- Characteristic values comply with the EN 1995:2014 standard in accordance with ETA-11/0030.
- The tensile design strength of the connector is the lower between the timber-side design strength ($R_{ax,d}$) and the steel-side design strength ($R_{tens,d}$).

$$R_{ax,d} = \min \left\{ \begin{array}{l} \frac{R_{ax,k} \cdot k_{mod}}{Y_M} \\ \frac{R_{tens,k}}{Y_{M2}} \end{array} \right.$$

- The compression design strength of the connector is the lower between the timber-side design strength ($R_{ax,d}$) and the instability design strength ($R_{ki,d}$).

$$R_{ax,d} = \min \left\{ \begin{array}{l} \frac{R_{ax,k} \cdot k_{mod}}{Y_M} \\ \frac{R_{ki,k}}{Y_{M1}} \end{array} \right.$$

- The design sliding strength of the joint is either the timber-side design strength ($R_{V,d}$) and the design strength on the steel side projected ($R_{tens,45,d}$), whichever is lower:

$$R_{V,d} = \min \left\{ \begin{array}{l} \frac{R_{V,k} \cdot k_{mod}}{Y_M} \\ \frac{R_{tens,45,k}}{Y_{M2}} \end{array} \right.$$

- The design shear strength of the connector is obtained from the characteristic value as follows:

$$R_{V,d} = \frac{R_{V,k} \cdot k_{mod}}{Y_M}$$

- The coefficients Y_M and k_{mod} should be taken according to the current regulations used for the calculation.
- For the mechanical resistance values and the geometry of the screws, reference was made to ETA-11/0030.
- Dimensioning and verification of the timber elements must be carried out separately.
- The screws must be positioned in accordance with the minimum distances.
- The characteristic thread withdrawal strengths were evaluated considering a penetration length of $S_{g,tot}$ or S_g , as shown in the table. For intermediate values of S_g it is possible to linearly interpolate.
- The shear strength and sliding values were evaluated considering the centre of gravity of the connector placed in correspondence with the shear plane.
- The characteristic shear resistances are calculated for screws inserted without pre-drilling hole. In the case of screws inserted with pre-drilling hole, greater resistance values can be obtained.
- The values in the table are evaluated considering mechanical strength parameters of the Ø15 VGS screws obtained analytically and validated by experimental tests.
- For different calculation configurations, the MyProject software is available (www.rothoblaas.com).

NOTES | TIMBER

- The characteristic thread withdrawal resistances were evaluated considering both an ϵ angle of 90° ($R_{ax,90,k}$) and of 0° ($R_{ax,0,k}$) between the grains of the timber element and the connector.
- The characteristic sliding strengths were evaluated by considering an angle ϵ of 45° between the grains of the timber element and the connector.
- The plate thickness (S_{PLATE}) are understood to be the minimum values to allow the countersunk head of the screw to be accommodated.
- The characteristic timber-to-timber shear strengths were evaluated considering both an ϵ angle of 90° ($R_{V,90,k}$) and 0° ($R_{V,0,k}$) between the grains of the second element and the connector.
- For the calculation process a timber characteristic density $\rho_k = 385 \text{ kg/m}^3$ has been considered. For different ρ_k values, the strength values in the table (withdrawal, compression, sliding and shear) can be converted via the k_{dens} coefficient.

$$\begin{aligned} R'_{ax,k} &= k_{dens,ax} \cdot R_{ax,k} \\ R'_{ki,k} &= k_{dens,ki} \cdot R_{ki,k} \\ R'_{V,k} &= k_{dens,ax} \cdot R_{V,k} \\ R'_{V,90,k} &= k_{dens,V} \cdot R_{V,90,k} \\ R'_{V,0,k} &= k_{dens,V} \cdot R_{V,0,k} \end{aligned}$$

ρ_k [kg/m ³]	350	380	385	405	425	430	440
C-GL	C24	C30	GL24h	GL26h	GL28h	GL30h	GL32h
$k_{dens,ax}$	0,92	0,98	1,00	1,04	1,08	1,09	1,11
$k_{dens,ki}$	0,97	0,99	1,00	1,00	1,01	1,02	1,02
$k_{dens,v}$	0,90	0,98	1,00	1,02	1,05	1,05	1,07

Strength values thus determined may differ, for higher safety standards, from those resulting from an exact calculation.

NOTES | TC FUSION

- Characteristic values according to ETA-22/0806.
- The axial thread withdrawal resistance in the narrow face is valid for minimum CLT thickness $t_{CLT,min} = 10 \cdot d_1$ and minimum screw pull-through depth $t_{pen} = 10 \cdot d_1$.
- Connectors with shorter lengths than those in the table do not comply with the minimum penetration depth requirements and are not reported.
- A concrete grade of C25/30 was considered in the calculation. For applications with different materials please see ETA-22/0806.
- The tensile design strength of the connector is the lower between the timber-side design strength ($R_{ax,d}$) and the concrete-side design strength ($R_{ax,C,d}$).

$$R_{ax,d} = \min \left\{ \begin{array}{l} \frac{R_{ax,0,k} \cdot k_{mod}}{Y_M} \\ \frac{R_{ax,C,k}}{Y_{M,concrete}} \end{array} \right.$$

- The concrete element must have adequate reinforcement bars.
- The connectors must be arranged at a maximum distance of 300 mm.

RELATED PRODUCTS



JIG VGU
page 409



LEWIS
page 414



CATCH
page 408



TORQUE LIMITER
page 408



B 13 B
page 405

INSTALLATION SUGGESTIONS

LONG SCREWS



Thanks to CATCH, even longer screws can be screwed on quickly and safely without the risk of the bit slipping. Can be combined with TORQUE LIMITER.

VGS + VGU



The JIG VGU template makes it easy to prepare a 45° angle pre-drill, thus facilitating subsequent tightening of the VGS screws inside the washer. A pre-drill length of at least 20 mm is recommended.



To ensure control of the applied torque, the correct TORQUE LIMITER model must be used depending on the chosen connector.

VGS +WASPL



Insert the screw so that the head protrudes 15 mm and engage the WASPL hook.



After lifting, the WASPL hook releases quickly and easily ready for use again.

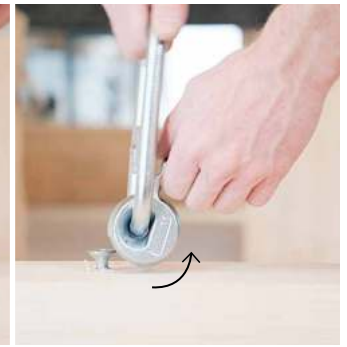

IMPORTANCE OF THE PILOT HOLE

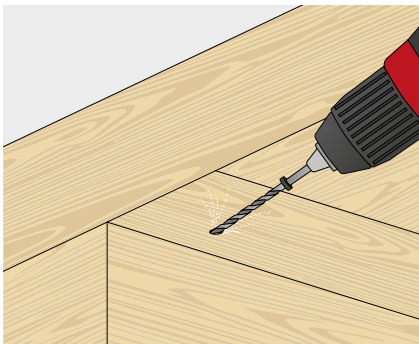

pilot hole

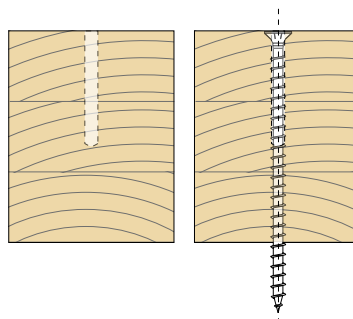

insertion
with pilot hole

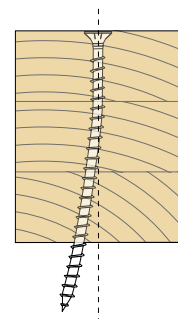

insertion
without pilot hole

Deviation of the screw from the direction of screwing often occurs during installation. This phenomenon is linked to the very conformation of the wood material, which is inhomogeneous and non-uniform, e.g. due to the localised presence of knots or physical properties dependent on grain direction. The operator's skill also plays an important role.

The use of pilot holes facilitates the insertion of screws, particularly long ones, allowing a very precise insertion direction.

INSTALLATION INSTRUCTIONS

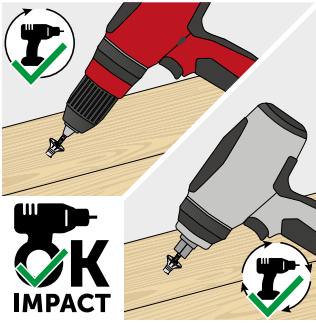

In the case of installation of screws used in timber-to-timber (softwood) structural connections, a pulse screw gun/screw driver can also be used.

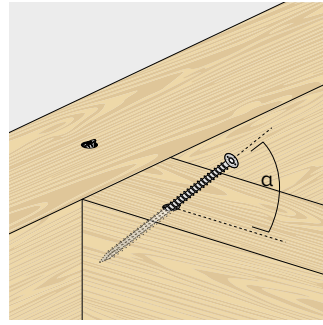

Respect the insertion angle with the help of a pilot hole and/or installation template.

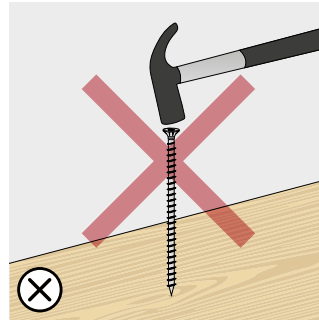

Do not hammer the screw tips into the timber.

The screw cannot be reused.

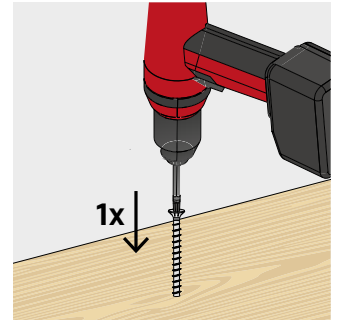

In general, it is recommended to install the connector in a single operation, without stopping and restarting which could create additional stress in the screw.

STEEL-TO-TIMBER APPLICATION



The use of pulse screw guns/impact wrenches is not permitted.

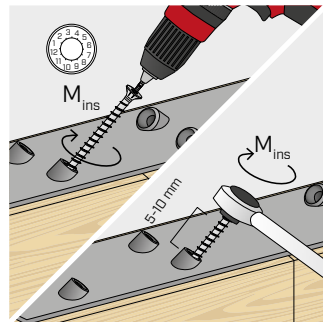

Ensure correct tightening. We recommend the use of torque-controlled screwdrivers, e.g. with TORQUE LIMITER. Alternatively, tighten with a torque wrench.

VGS	d ₁ [mm]	M _{ins,rec} [Nm]
Ø9	9	20
Ø11 L < 400 mm	11	30
Ø11 L ≥ 400 mm	11	40
Ø13	13	50

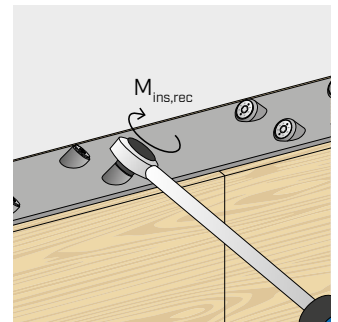

After installation, the fasteners can be inspected using a torque wrench.

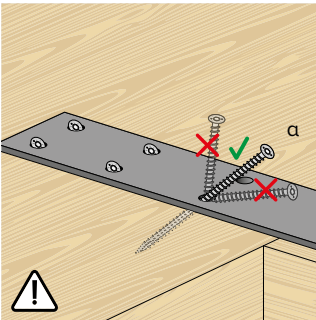

Avoid bending.

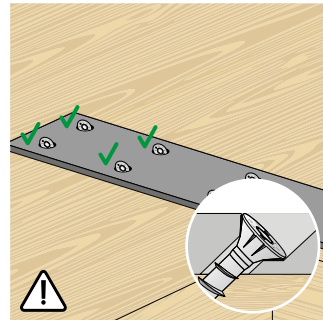

The installation of multiple screws must be performed to guarantee that loads are distributed evenly to all fasteners.

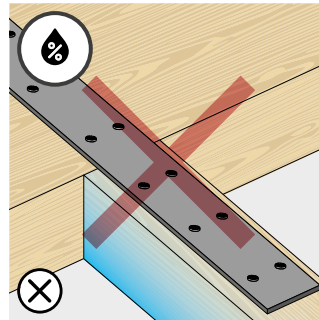

Shrinkage or swelling of timber elements due to changes in moisture content must be avoided.

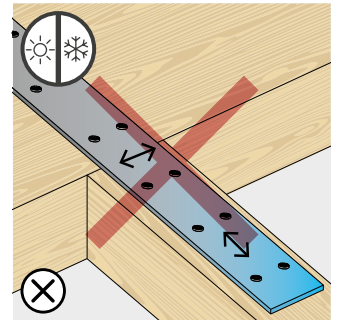

Avoid dimensional changes in the metal, e.g. due to large temperature fluctuations.

SHAPED PLATE

WASHERS

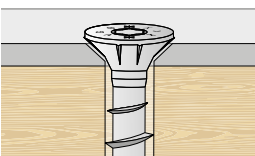

Countersunk hole.

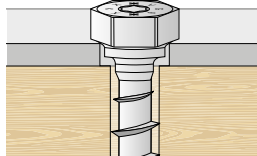

Cylindrical hole.

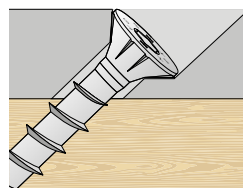

Inclined countersunk hole.

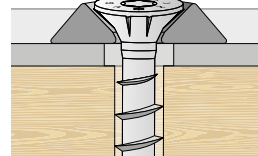

Cylindrical hole with countersunk washer HUS.

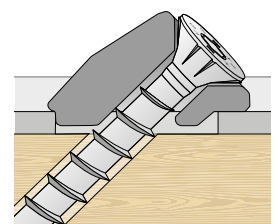

Slotted hole with VGU washer.

APPLICATION EXAMPLES: REINFORCEMENT

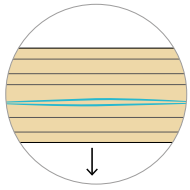

TAPERED BEAMS
apex tension reinforcement perpendicular to grain

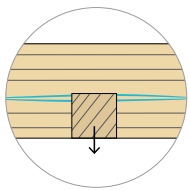
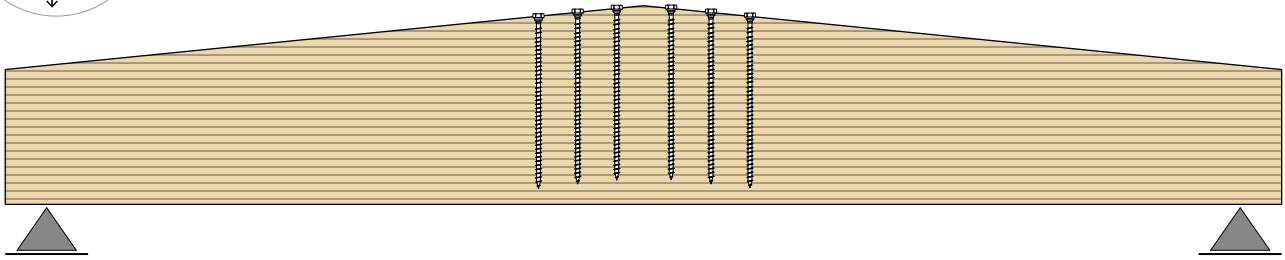

HANGING LOAD
tension reinforcement perpendicular to grain

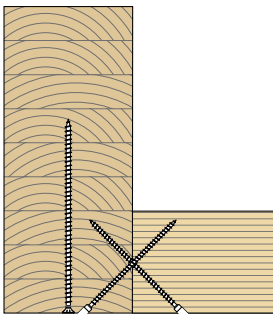

section

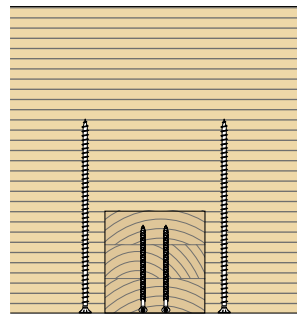

front

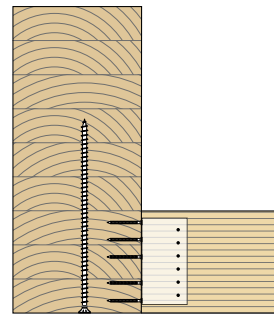

section

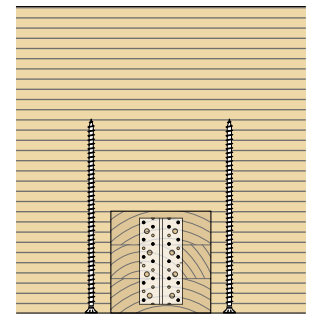

front

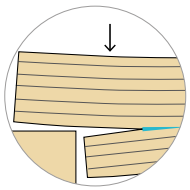

NOTCH
tension reinforcement perpendicular to grain

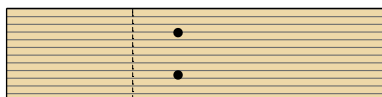

plan

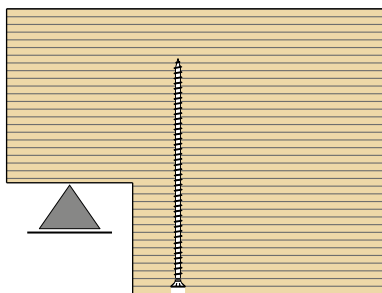

section

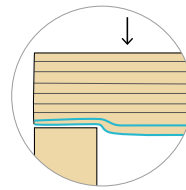

SUPPORT
compression reinforcement perpendicular to grain

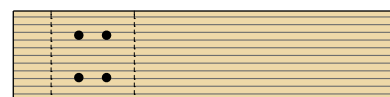

plan

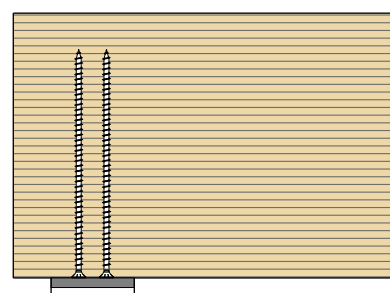

section